

Pipe Coil Technology Limited

**Bespoke coiling solutions
for plastic flexibles**





Pipe Coil Technology Limited produce a wide range of standard coiling machines which are suitable for the most common coiling applications for plastic flexible types such as gas, water & sewage pipe, plumbing pipe, garden hose, industrial hose, automotive tube, land drainage pipe, electrical conduit and medical tube. However, in order to meet the demand for machines built to specific customer requirements and to satisfy the diverse needs of the global markets into which we supply, we provide bespoke coiling machine solutions, ranging from modified standard machines to completely new special purpose machine designs.

We have a large engineering team with a wealth of experience in coiling technology and a proven track in developing creative and cost effective solutions to a wide range of coiling challenges. We work closely with our end customers and with extrusion line manufacturers throughout projects to ensure compatibility of the coiling solution with overall production process.

A selection of completed projects are included here to give a flavour of the bespoke coiling systems we can provide.

Dual station semiautomatic coiler for coiling district heating pipe fitted with automatic strapping system

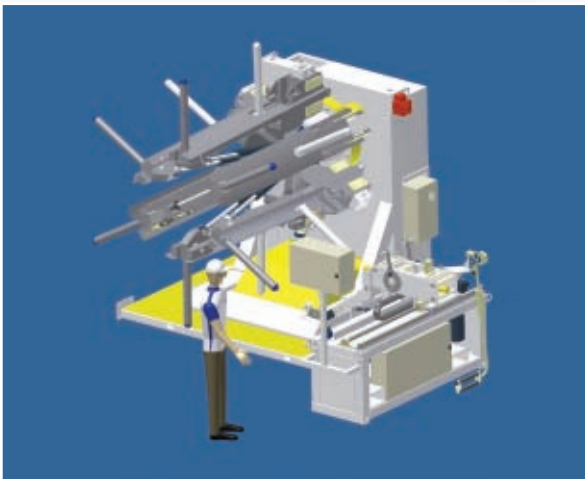

Single head semiautomatic coiler for geothermal pipe mounted on 'turntable' base to enable coil unload to rear

Dual payoff and accumulator system for use in PEX-AL-PEX line





Single head semiautomatic coiler with integrated coil unload system for producing coils of RTP pipe weighing up to 6t.

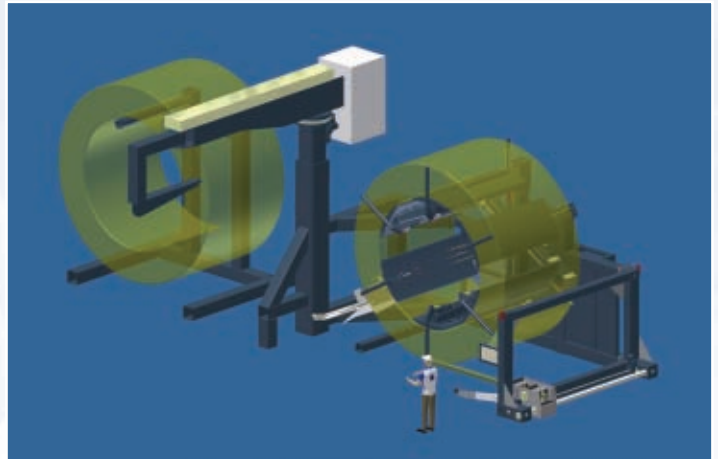

Automatic 'pick and place' overhead crane for handling 5.2m diameter drums in an off-line coiling system



Automatic coiler for pre-cut lengths of spiral wound hose with conveyor unload system

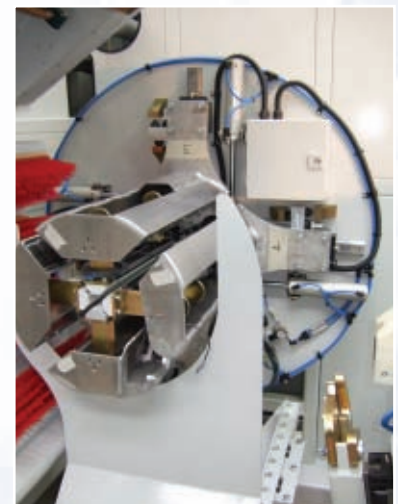

Pipe Coil Technology Limited



Why industry leaders choose Pipe Coil Technology Limited

- We are committed to achieving the highest level of customer satisfaction and to building long term, mutually beneficial, partnerships with our customers
- We are experts at what we do; understanding customer needs, supplying technically superior solutions on time and in budget and providing excellent after sales support throughout product lifetime.
- Our project management, engineering and technical sales teams include specialists from the extrusion, oil & gas and automation industries who between them have many years experience in creating, delivering and implementing complex equipment solutions.

Products

For plastic pipe, tube, hose & conduit manufacture:

- Automatic coiling & packaging technology
- Semiautomatic coiling technology
- Off-line, high speed coiling technology
- Low ovality coiling technology (for HDPE pipe)
- Drum winding technology
- Engineered coiling solutions

For wire rope and large diameter cable manufacture:

- Drum take-up and payoff stands
- Turntables and spoolers
- Wire spooling and rewinding

For sub-sea umbilical, flow-line and cable manufacture:

- Carousels and loading systems
- Drum handling, moving and spooling equipment
- Production machinery; S-Z lay machines, rotating taping heads, caterpillar haul-offs, drum take-up & payoff stands
- Wire spooling and rewinding

For sub-sea umbilical, flow-line and cable installation:

- Carousels and loading systems
- Drum handling and spooling equipment
- Cable guides and transfer equipment

Pipe Coil Technology Limited

2nd Floor Pametrada Building, Oceana Business Park, Davy Bank,
Wallsend, Tyne & Wear, NE28 6UZ United Kingdom
Tel: +44 (0) 191 295 9910 Fax: +44 (0) 191 9911 Email: sales@pipecoil.co.uk